

Crossbow Technology

“...the most robust and reliable AHRS technology in the industry...”

Vern Raburn/CEO Eclipse Aviation



“...they are dynamite, very useful data and an excellent decision support tool. “

Weyerhaeuser

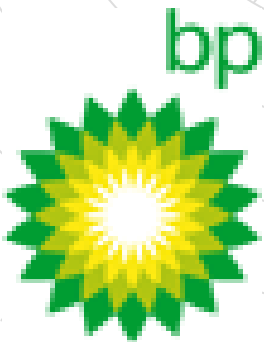

“...motes are the sexy part of sensor net technology. “

Ken Douglas, BP International Ltd

Mark Goodman (mgoodman@xbow.com)

October 26, 2005

Comments from the Investors

“Crossbow is a **technology leader in the emerging wireless sensor market and the work they are doing extends Cisco’s vision for the Intelligent Information Network** to the almost countless number of objects that will require wireless sensor technology,” says Dave Rossetti, vice president, strategic software technology, **Cisco Systems**.

Intel originally invested in Crossbow in 2002. “Intel Capital’s investment in Crossbow represents our confidence in the growth of wireless sensor network technology,” said David Tennenhouse, Vice President, Corporate Technology Group and Intel’s Director of Research. “**We’re pleased to expand our cooperation with Crossbow and continue to develop Intel® XScale® technology in wireless sensor networks.**”

Paladin Capital Group, a private equity firm based in Washington, DC, is also participating in this investment round. Paladin's \$235 million Homeland Security Fund is focused on investments in existing companies with immediate solutions to address homeland security issues and needs. “**Crossbow has both the experience and the innovation that we look for,**” said Joann Teal, Vice President of Paladin Capital Group. “**We evaluated many companies in the sensor market, and Crossbow was the clear choice for Paladin.**”

Source: June 8, 2005 Press Release



**What can I tell you that you haven't
already heard over the last 3 days?**

Convergence of Technologies

Sensors: Miniaturization, micromachining, and low cost manufacturing leads to smaller sizes, low power, lower costs. Allows us to monitor with higher granularity. Many types of sensors and more on the way.



YES

Computing/Internet: Computing power is becoming small and inexpensive enough to add to almost any object. Networks of computers facilitate collaboration through information and resource sharing.

Wireless (RF): Spans a host of technologies including Bluetooth and WiFi networks, cellular and satellite communications. CMOS radios enable embedded wireless networking.

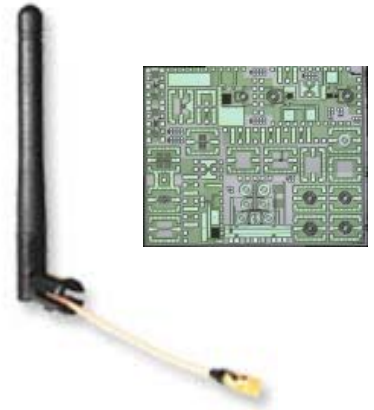
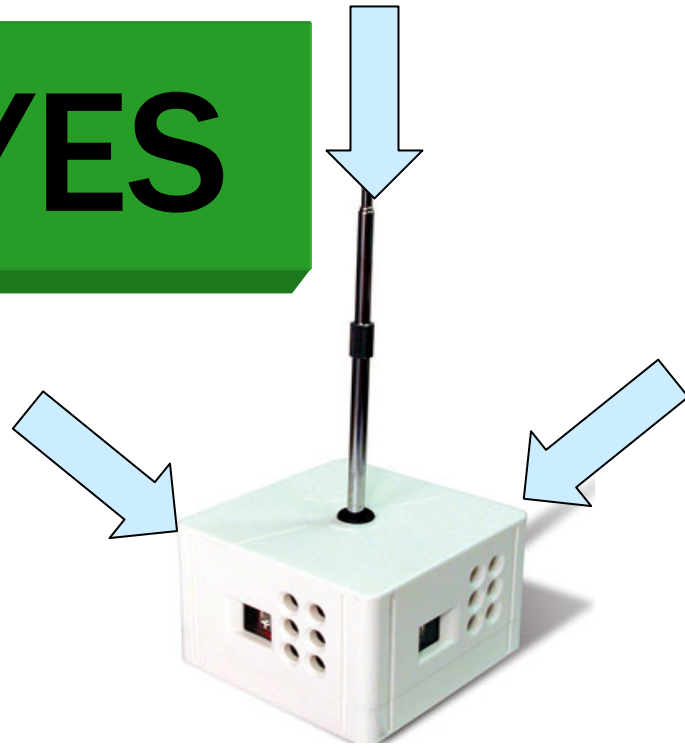

This sensor mesh network solution consists of a network of nodes which have sensors to monitor the environment. Mesh networking software resides in the nodes. Messages are sent hop by hop to the base station

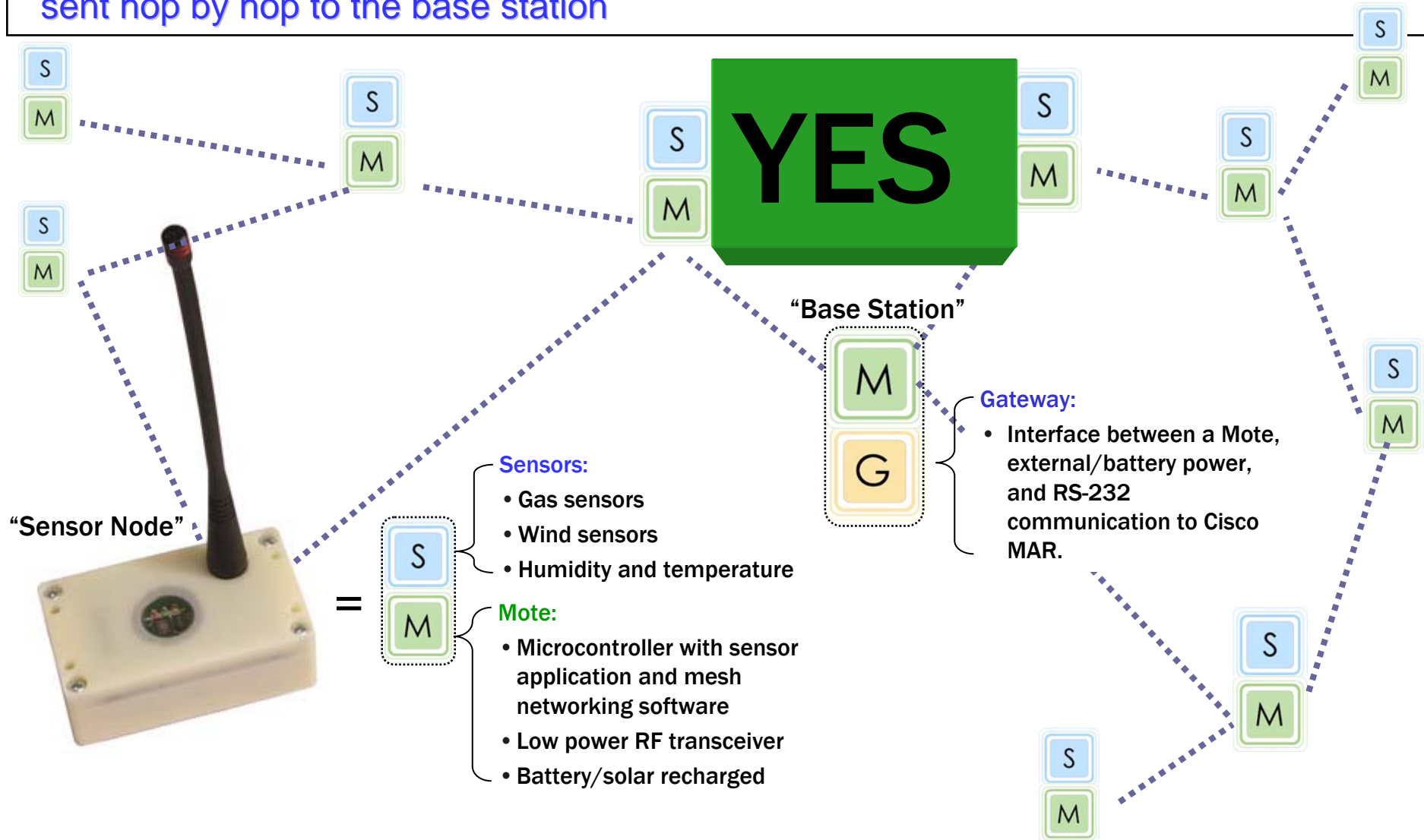

Information Spectrum

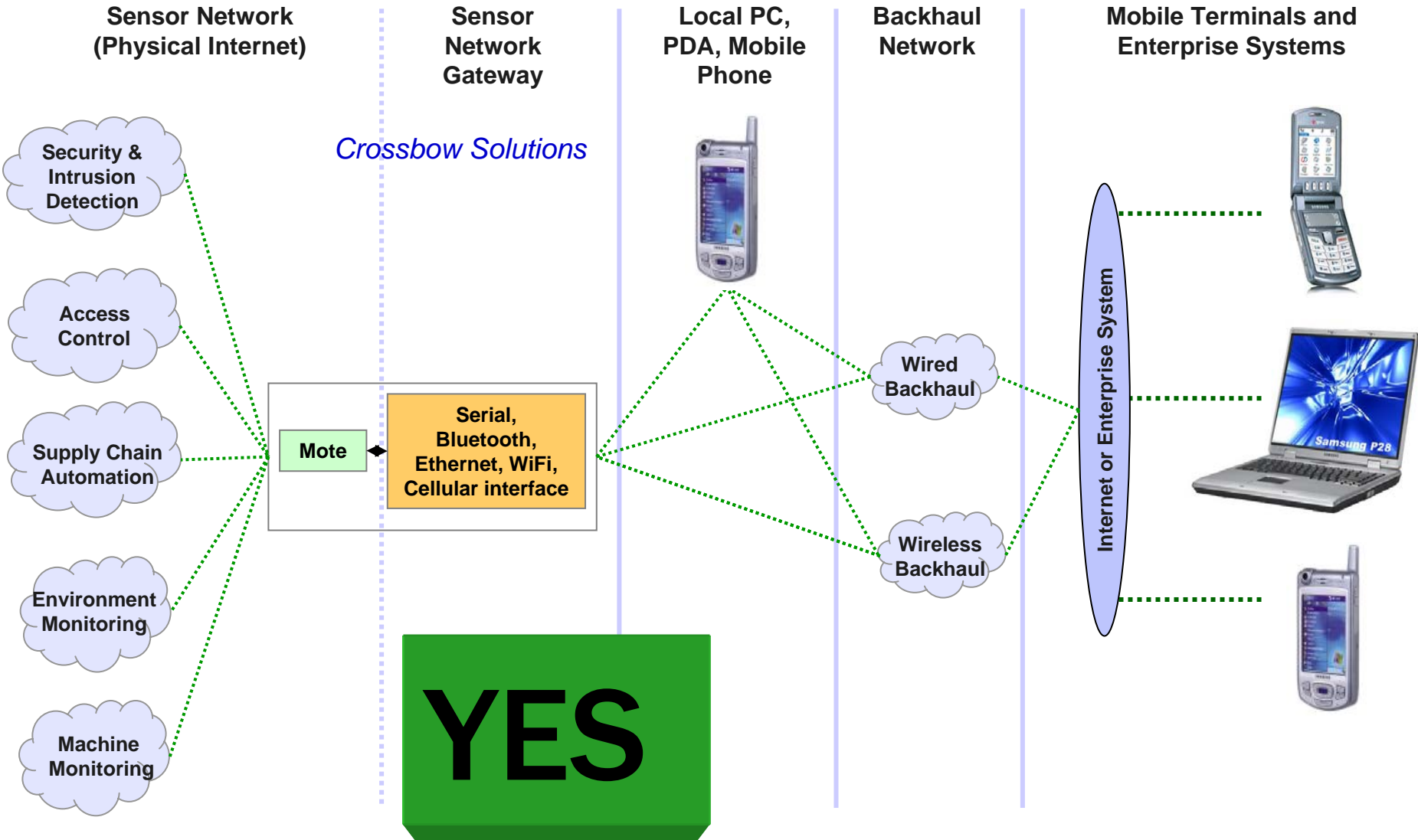

Wireless Technologies

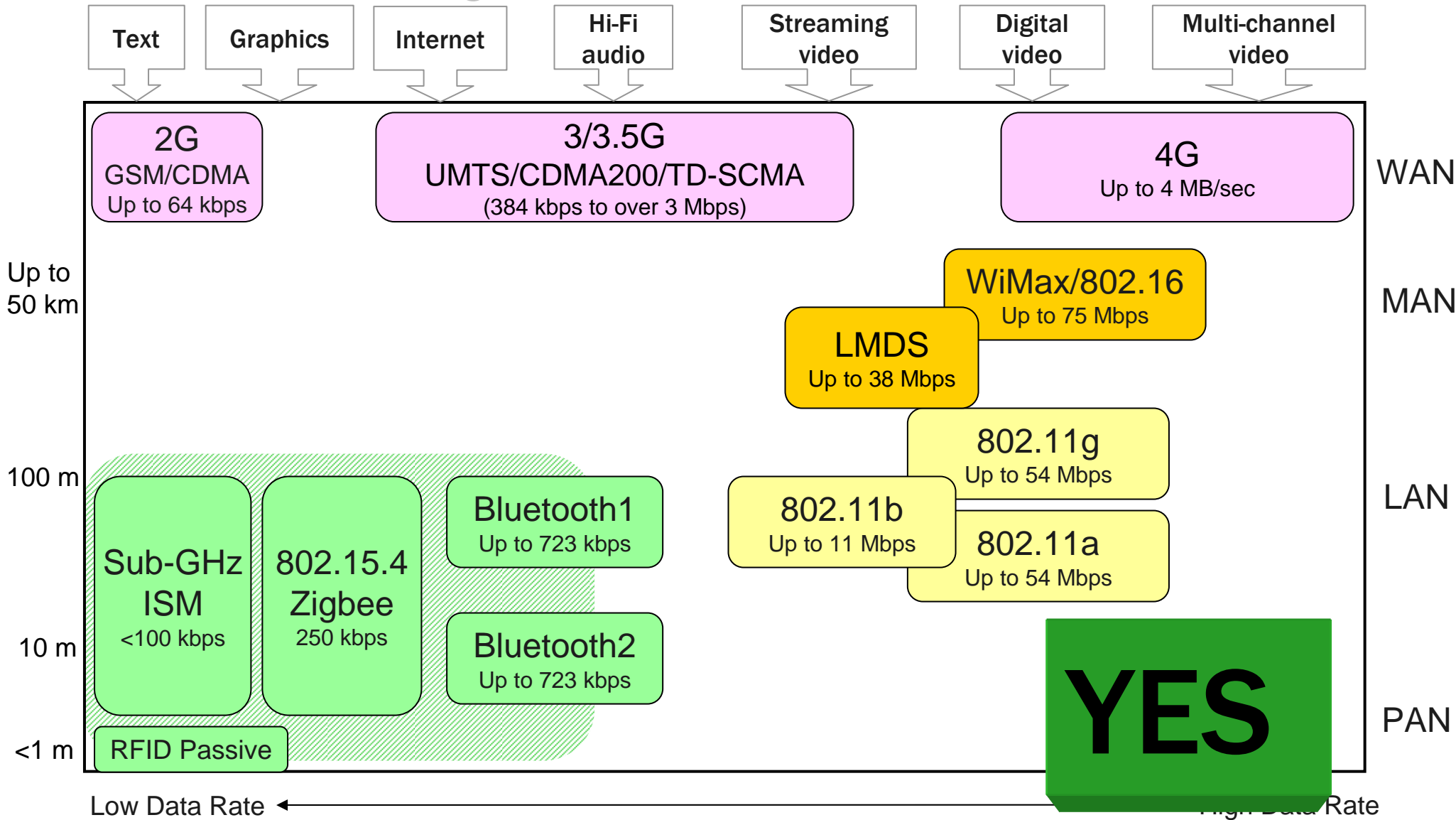

Market Data Summary

YES

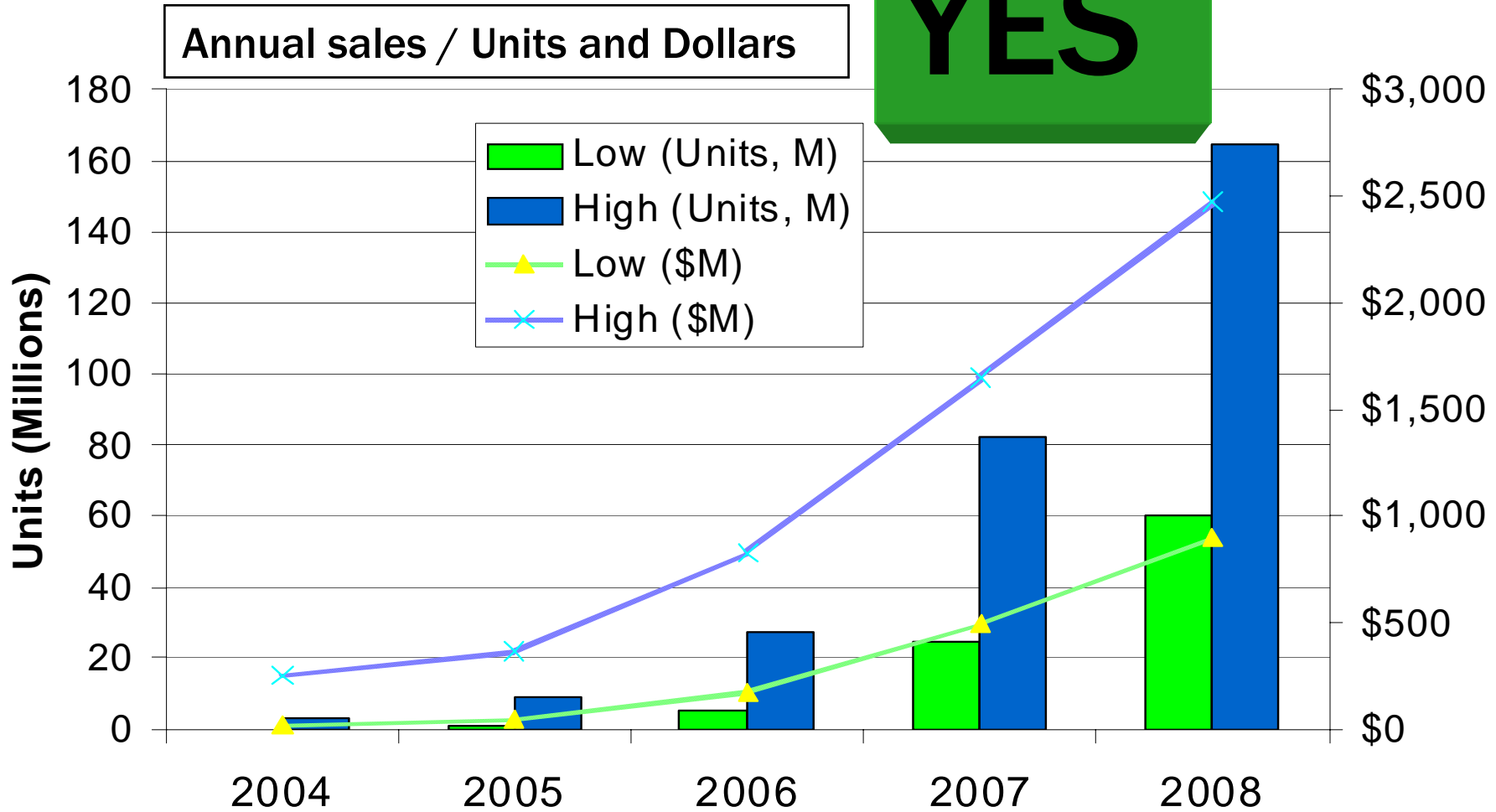

\$500M to \$1.25B
ASPs: \$10 to \$25

Application Categories

Courtesy of Prof. David Culler, UCB

YES

- **Monitoring Things & Spaces (M)**

- Precision agriculture, habitat studies, ...
- HVAC, facilities usage efficiency, ...
- Condition-based maintenance, structural response, ...
- Security, safety, ...



- **Tagging and Tracking (T)**

- Asset tracking, Smart Tags, ...
- Supply Chain Monitoring, Inventory Management....
- Indoor Location Services,

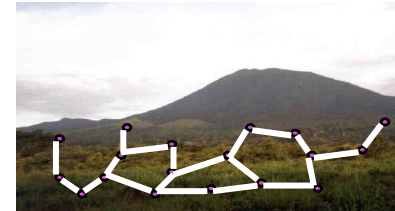

- **Ubiquitous Computing (U)**

- Context aware computing, non-verbal computing
- Assisted living facilities, home healthcare
- Smart Furniture





**Where are we today....
and how do we get to the future?**

The Technology Adoption Lifecycle

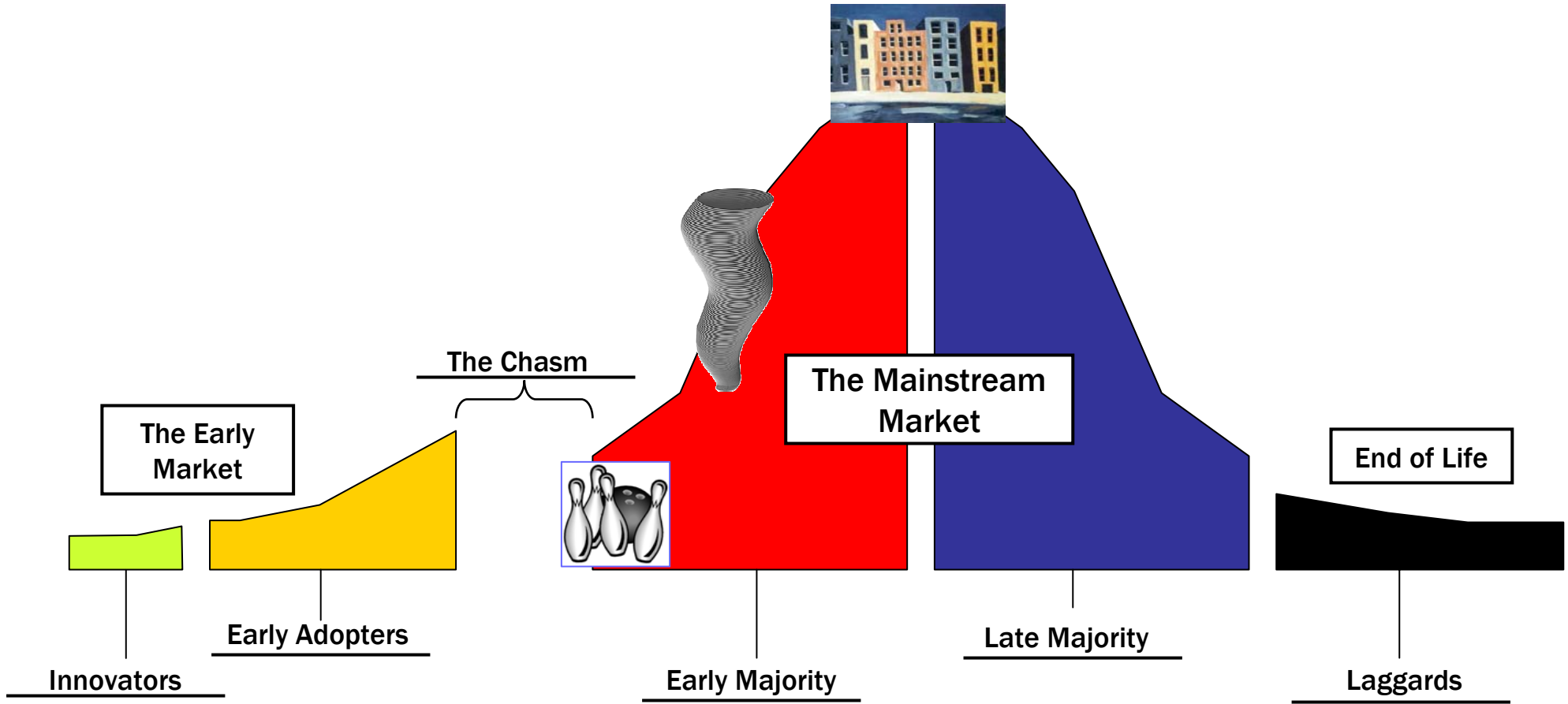

Adapted from "Crossing the Chasm," Geoffrey A. Moore, 1991.

Don't just fall in love with the technology, but- Ask These Questions....

- Does this help me save operating costs?
- How does this help me drive a competitive advantage?
- How does this eliminate the surprises in my business?
- Does this take the guess work out of my job?
- How does this help me with my head count reduction goals?

and

- What can I do with wireless, that I cannot do with wires?

Stages of Adoption

Stage	Strategic Thrust	Driver	Stakeholder
Proof of Concept	Prove that the solution will work in the the environment Validate solution assumptions	Engineering Invention	Labs Business Leader
Prototype	Understand the "go to market" needs Create and validate specific customer solutions	Engineering Marketing	Business Leader Business Unit
Production	Validate price and cost assumptions Understand and create "go to market" pre and post sales processes	Marketing Sales	Business Unit Customer

How can Academic and Government Experience be leveraged?

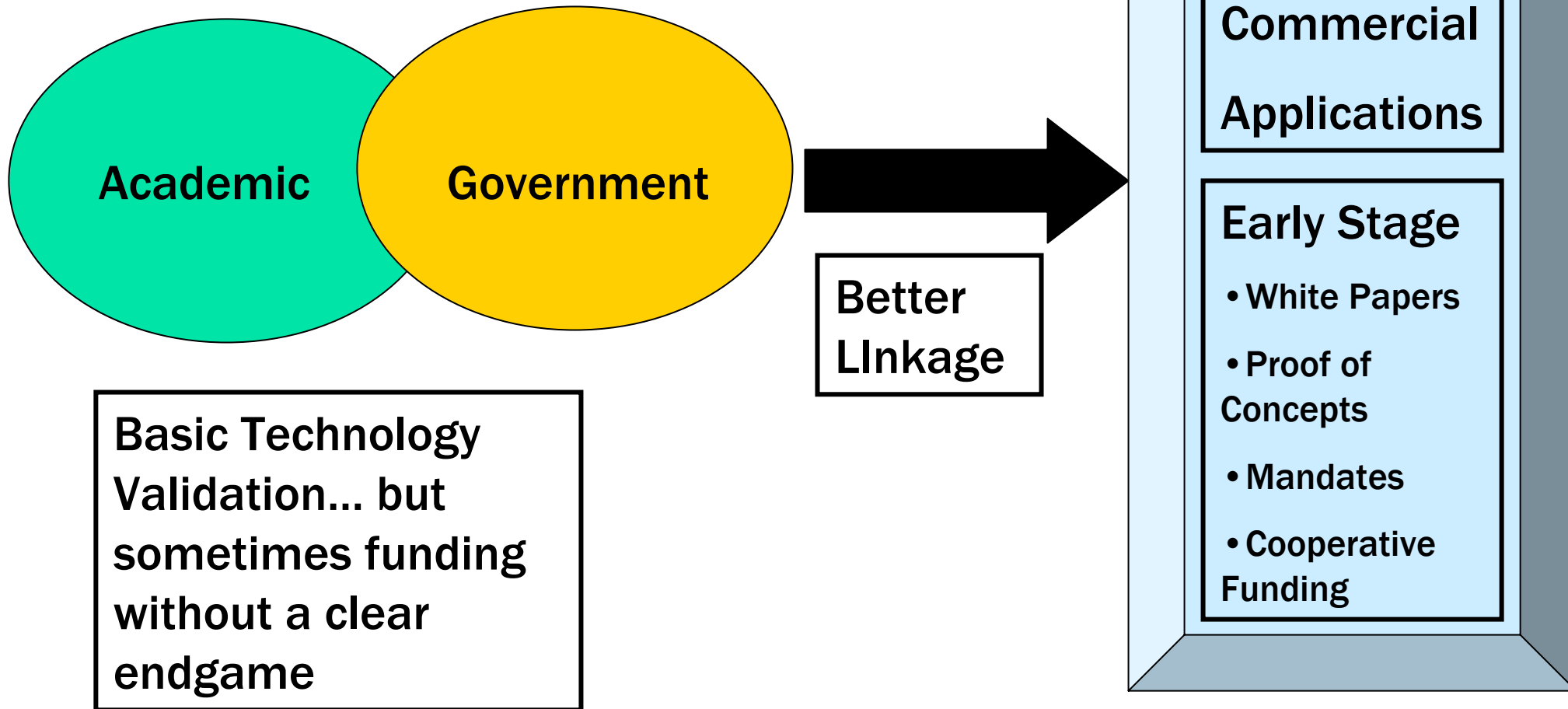

Crossbow Tools to aid adoption

- “Do it yourself” Mesh Network

- Sensors
- Motes
- Gateways
- Mote-View

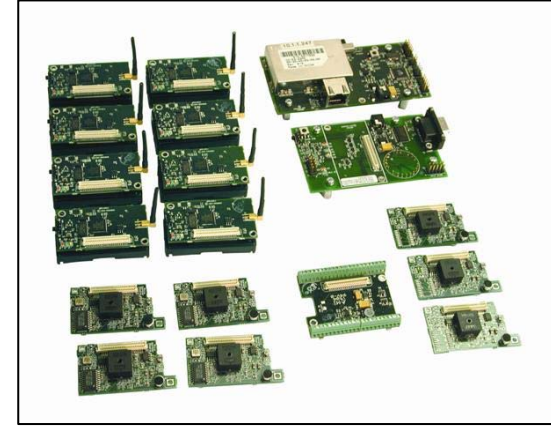

- OEM Edition Development Platform

- Software Tools
- Software Stack (includes XMesh and XServe)
- Mote Hardware
- Reference Design



A Vision for Wireless Sensor Networks

- Providing ways to monitor, capture, analyze, and understand the present so that we can make the most of every opportunity.

