

# Adaptive RF Links

Doug Robbins

781-271-7173 • [drobbins@mitre.org](mailto:drobbins@mitre.org)

Air Force MOIE

The logo for the MITRE Technology Program, featuring a stylized graphic of stacked blocks in yellow, orange, and blue to the left of the text.

**MITRE**  
Technology  
Program

# Problem

- **A growing bandwidth shortfall across the DOD is exacerbated by non-adaptive military radio designs. These legacy radio designs strive to meet worst case communication conditions, providing a robust solution, but waste bandwidth in an unchallenged environment. An adaptive links radio addresses this problem.**

# Background

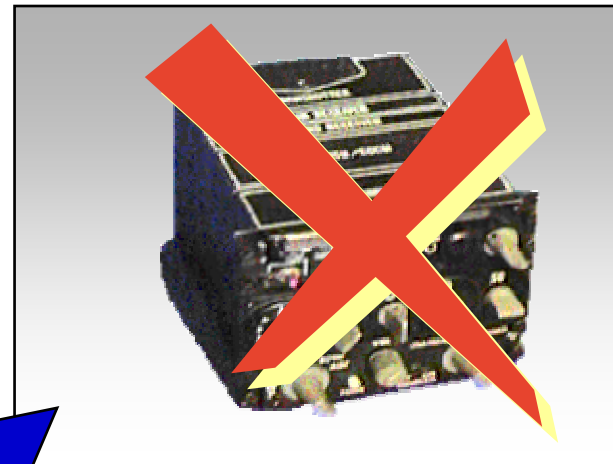
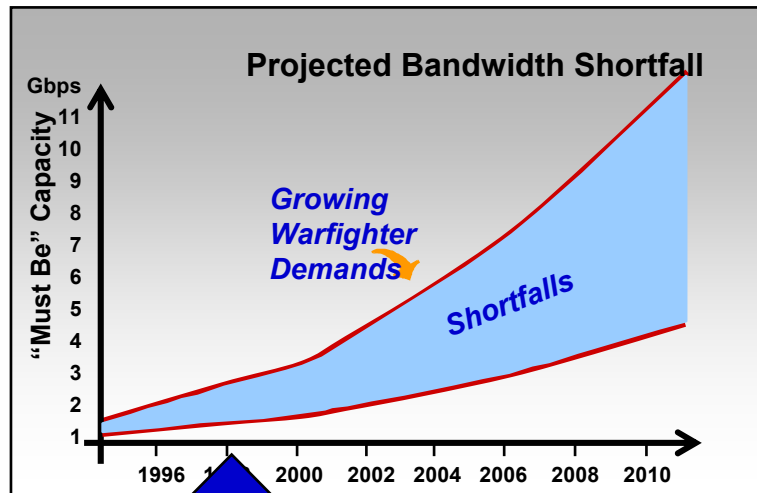

- Growing bandwidth shortfall across the DOD
- No adaptation means must design to meet worst case conditions
- Existing radio architectures not extensible

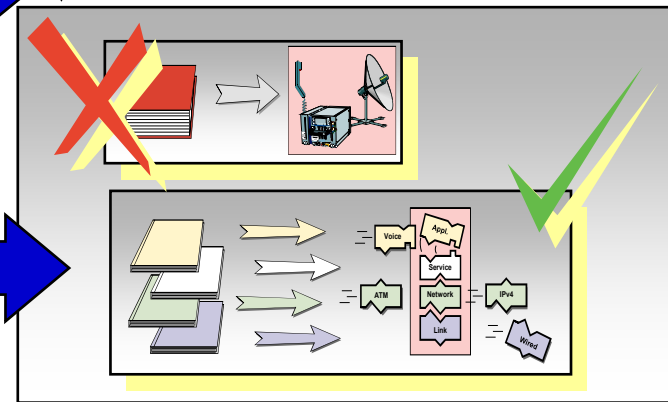

# Objective

**This two-year MOIE effort will demonstrate, through implementation of a proof of concept prototype, how link adaptation can improve performance of military communication systems. A per-packet adaptable radio framework was developed in FY01. In FY02 we will extend this framework to support:**

- Automated discovery of remote radio capabilities**
- Over-the-air negotiation of “mode” changes**
- Application of an adaptation policy**

# Activities

- **Building a per-packet adaptive modem based on Rockwell Collins Miniature Radio CODEC (MRC) and state of the art 4-Processor Digital Signal Processing board**
  - **Developing policy independent over-the-air “mode” change negotiation techniques**
  - **Implementing a policy driven (e.g. “Turn up power first, then add FEC”) adaptation scheme**

# Highlight

Today's Tactical Radio Operates @ One Point...

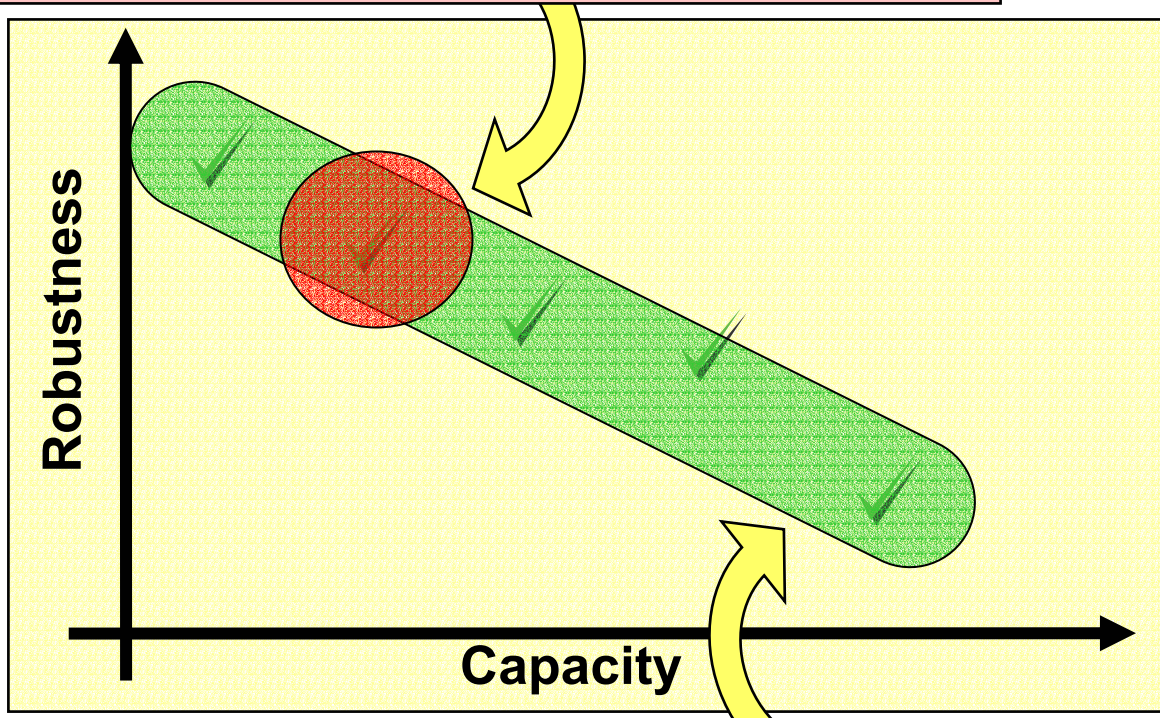

... an Adaptive Links Radio Provides a Range!

# Demonstration

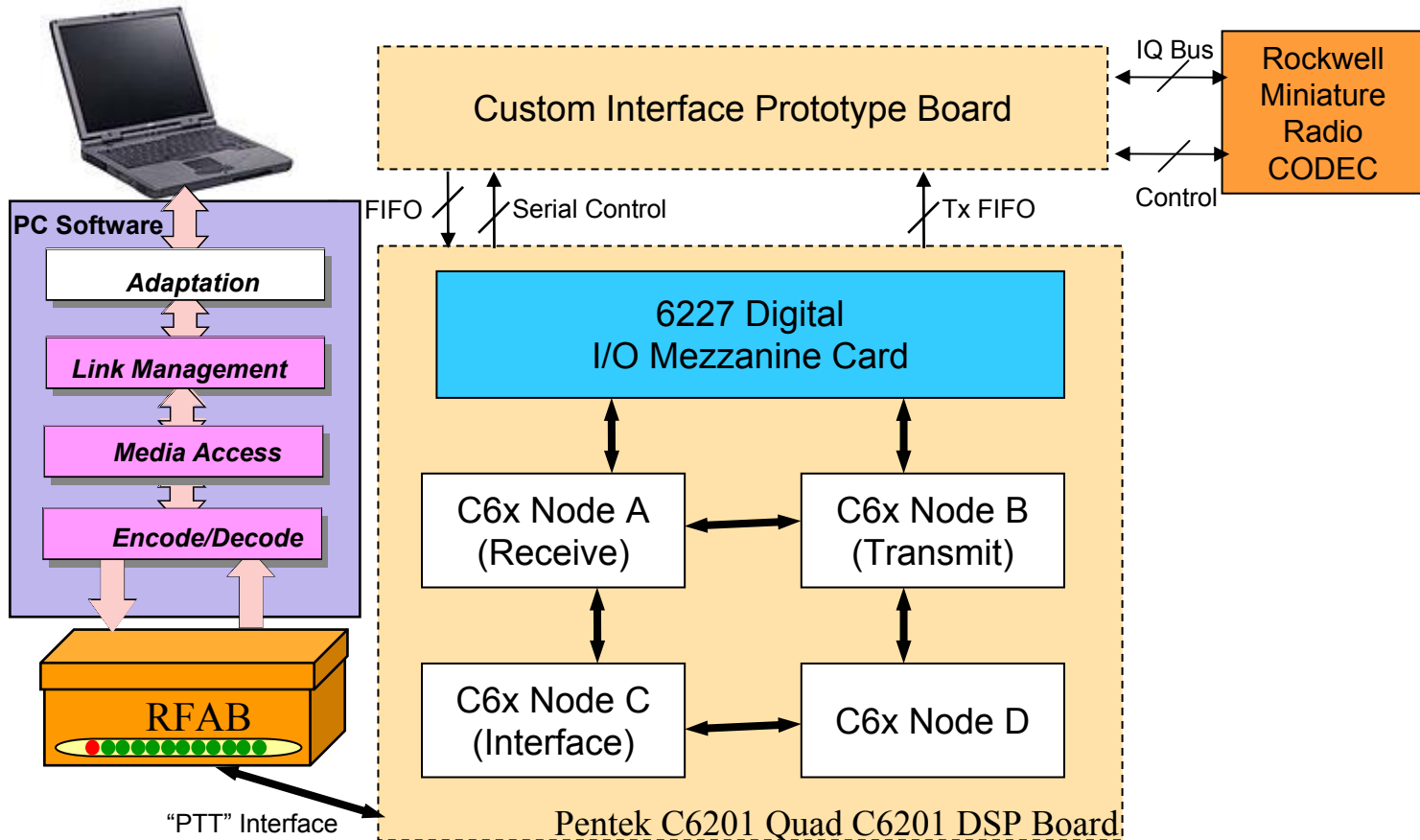

# Impacts

- **Take next step on path to efficient Global Grid**
  - Designed to meet the worst case... but can also adapt to gain efficiency when conditions permit
- **Support sponsor programs with adaptive links techniques**
  - Advanced EHF/AWS can adaptively trade robustness for capacity within a terminal
  - Provide insight into new CONOPS to reduce risk of collateral damage and fratricide in TACP mission

# Future Plans

