

# Guarded Sharing of Information with XML (GSIX)

James Garriss

757-896-8551 • [jgarriss@mitre.org](mailto:jgarriss@mitre.org)

DISA

The logo consists of a stylized graphic of stacked, colorful blocks (yellow, orange, and blue) on the left, followed by the text "MITRE Technology Program" in a bold, sans-serif font.

MITRE  
Technology  
Program

The MITRE logo, featuring the word "MITRE" in a bold, black, sans-serif font.

MITRE

© 2004, The MITRE Corporation

# Problem

- Recent directives require DoD systems to use **XML** for data exchange and to provide **Web service** interfaces.
- Many of these systems need to exchange data across security domains.
- Cross-domain solutions must **modernize** to make use of the capabilities of XML.

# Background

- Current solutions typically have the rules built into the trusted guarding software. If these could be separated, then the rules could be updated without changes to the software.

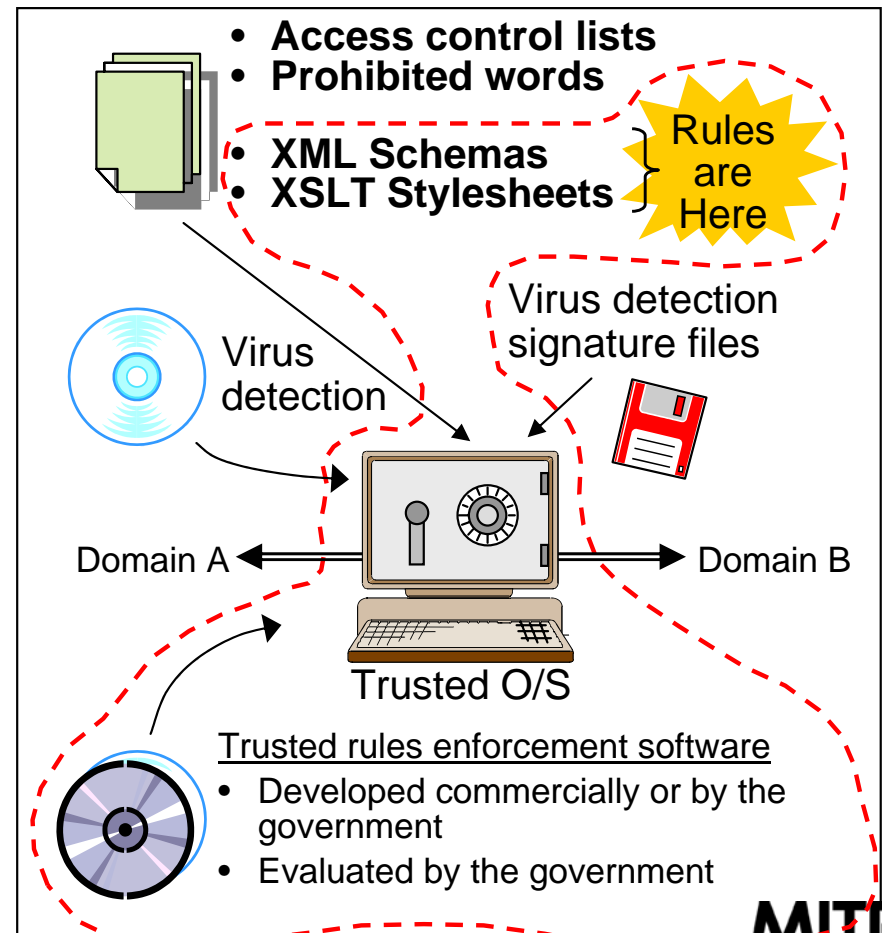
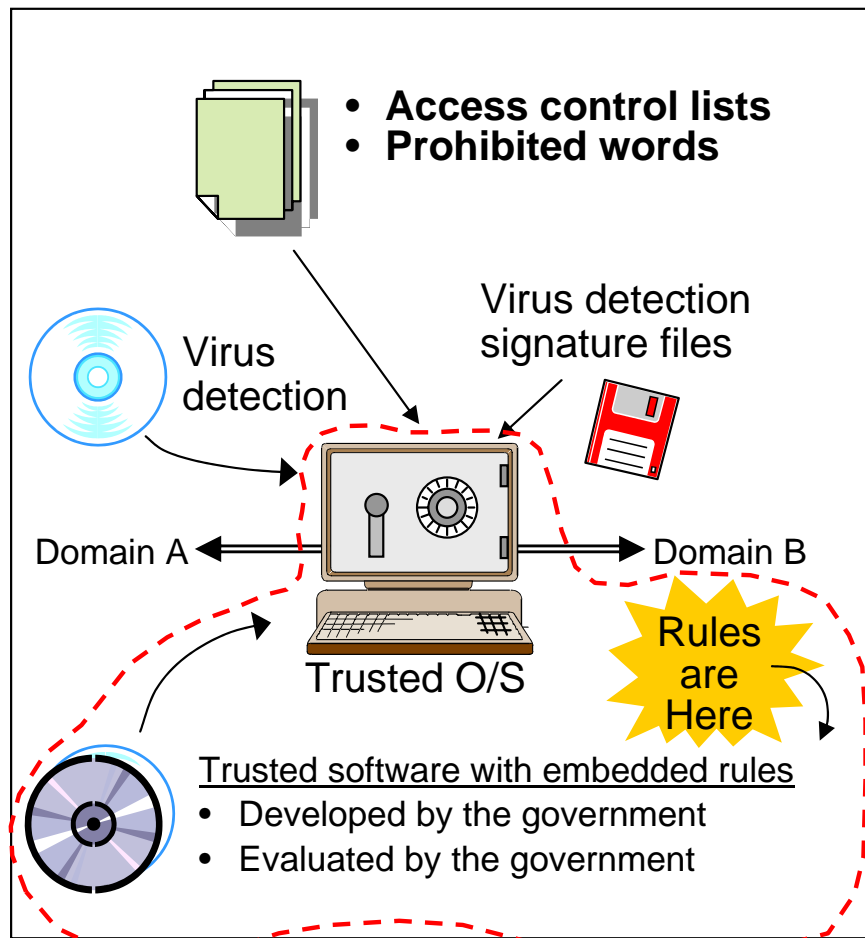

# Objectives

- Gather results from cross-domain research efforts studying the use of XML technologies.
- Implement a **prototype** based upon these ideas.
- Test and refine the ideas, providing feedback to the researchers.
- Offer the prototype back to the researchers as a platform for future research.

# Activities

- Add new features to the existing Guarded Sharing of Information with XML (**GSIX**) prototype, including:
  - Support for **Web services** through GSIX
  - An **XML Signature** component for elements with free text
  - A graphical user interface for monitoring and changing the active policies
- Test in the lab and at the Joint Warfighter Interoperability Demonstration (JWID) 2004

# Highlight

The core component of GSIX is the **Content Enforcer**, which uses XML technologies to enforce security policies upon XML documents.

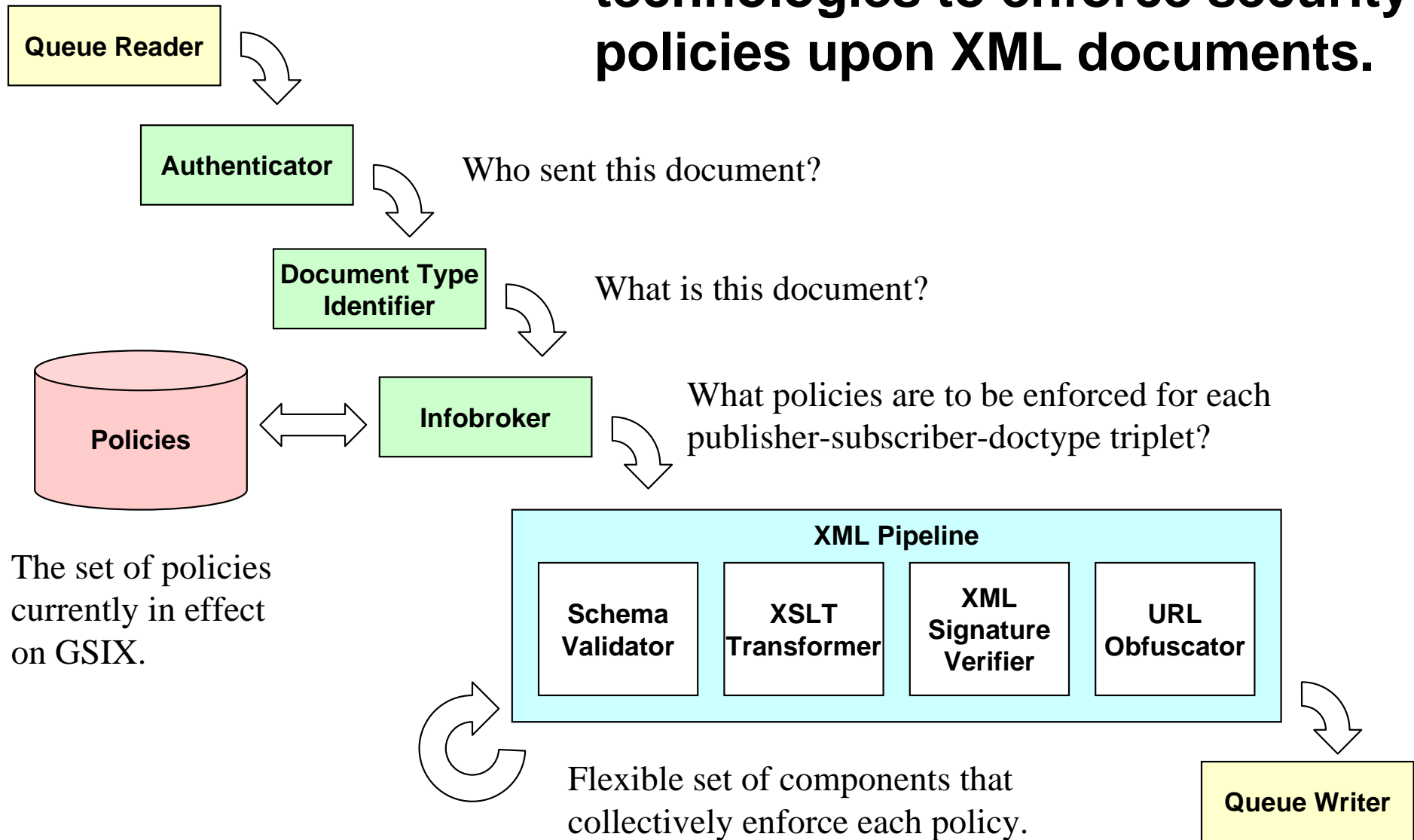

# Demonstration

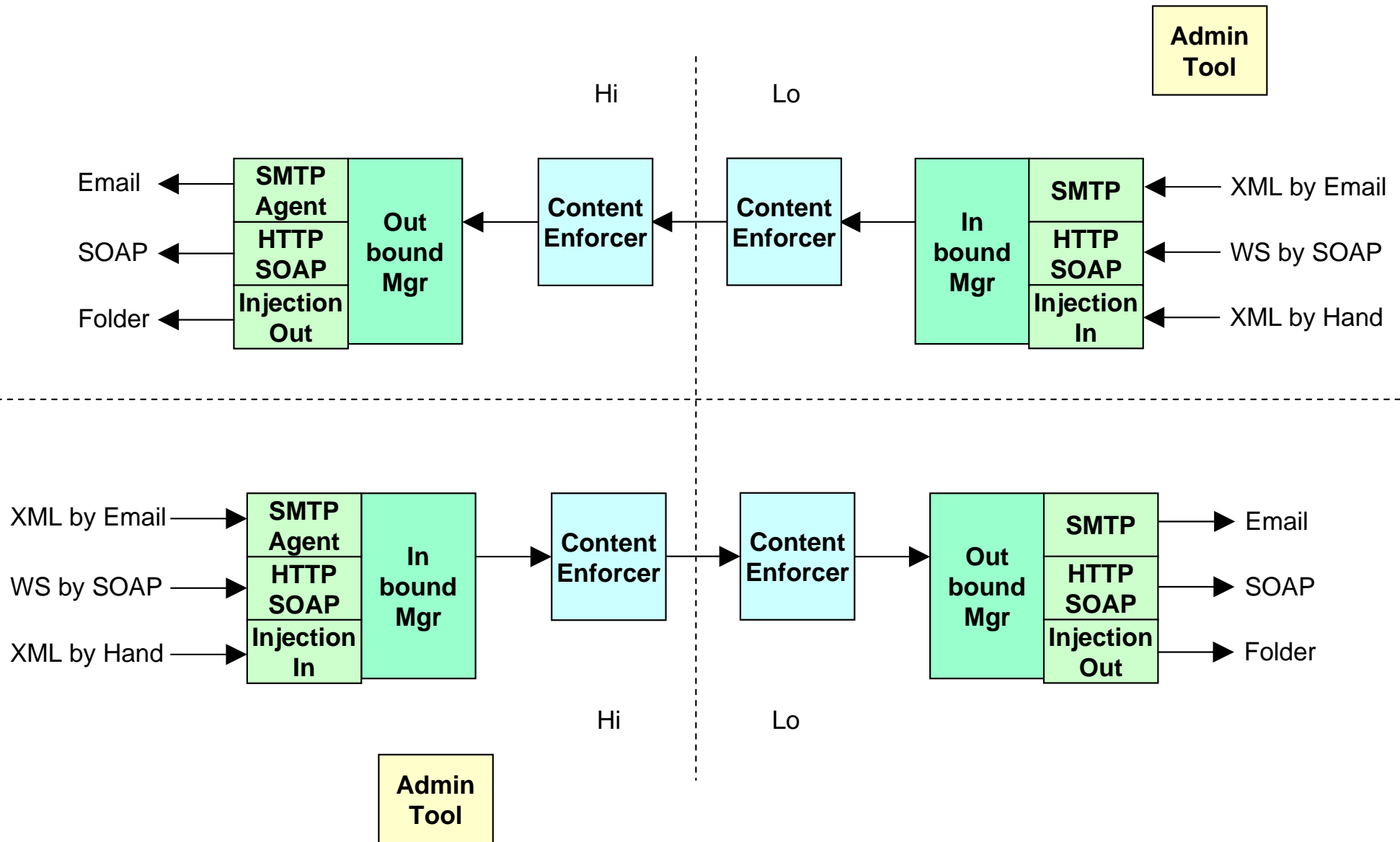

# Impacts

- The goal of GSIX is to **transition** new capabilities to existing content-based guards. We are not building a new guard.
  - The ISSE and C2 Guard PMOs are now exploring the use of XML parsers, XML Schema validators, and XSLT processors.
  - We have also coordinated with the Cross Domain Solutions Office at NSA.

# Future Plans

- Conduct additional research to determine the requirements for a “good” **XML schema**, such as:
  - Strong typing
  - Security labels
  - Unambiguous schema references
- Incorporate **Semantic Web** technologies into GSIX to allow ontology information to cross security boundaries