

Hybrid Ultra-Wideband Systems for Small Unit Operations

Jim Marshall

703-983-5488 • jmarshall@mitre.org

MITRE Sponsored Research



**MITRE
Technology
Program**

Problem

- **Small unit operations require reliable intra-squad communications and position determination.**
- **High-loss signal propagation through walls and foliage degrades communications and ranging performance.**
- **Ultra-wideband (UWB) signals show promise for these applications, but**
- **The need to keep spectral density low could limit effectiveness of UWB systems.**

Background:

FCC UWB Emission Limit for Outdoor Hand-held Systems

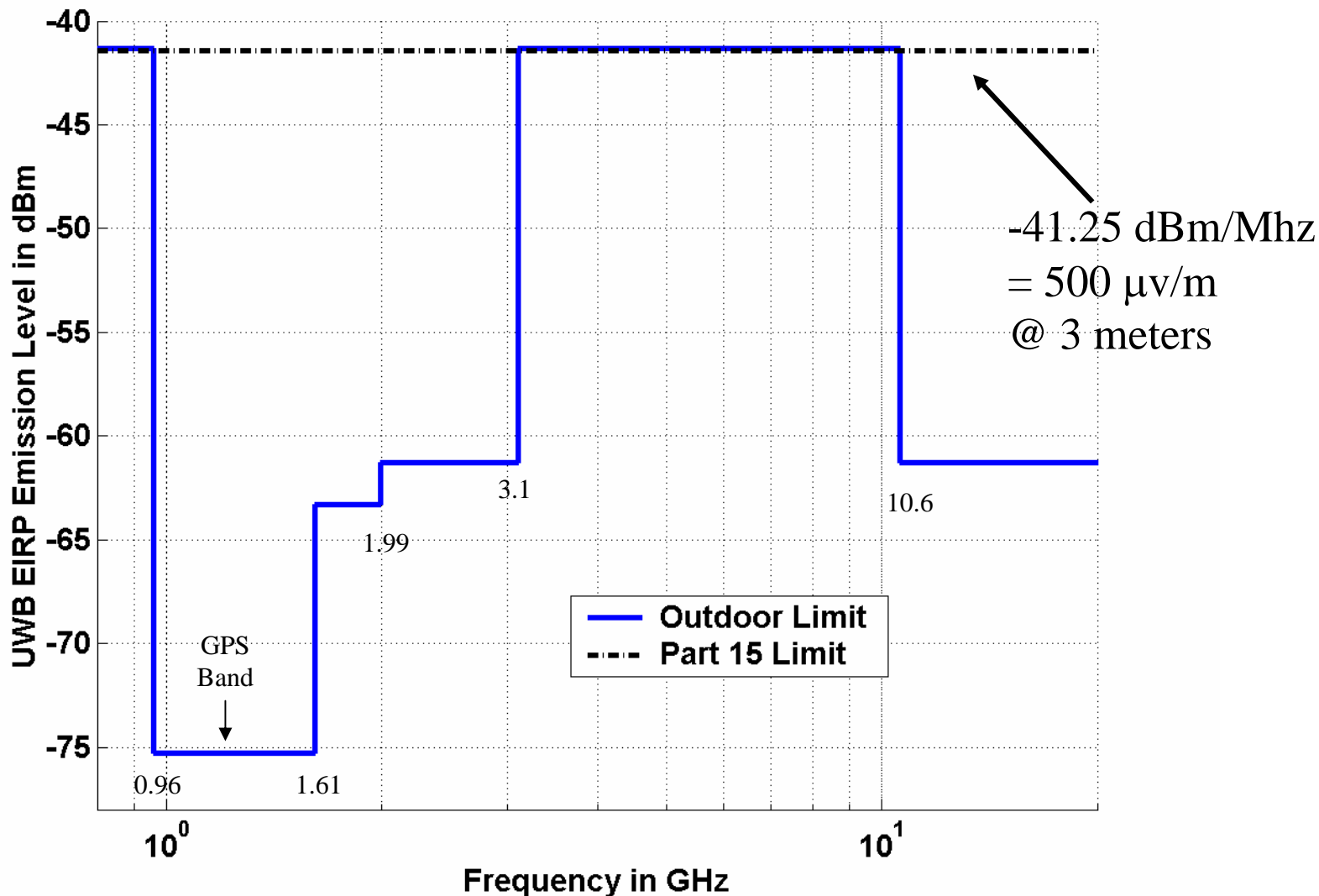

Spectral plots provided by Federal Communications Commission (FCC) with press release announcing First Report and Order adopted February 14, 2002, ET Docket 98-153.

MITRE

© 2005, The MITRE Corporation

Objective

- **Provide an UWB system that:**
 - **Complies with FCC regulations, and**
 - **Provides low rate communications and ranging inside buildings**
- **Accomplish this through the development of:**
 - **A hybrid UWB waveform**
 - **A prototype system for testing**

Activities

- Frequency band selection and waveform design
- Development of receiver algorithms
- Hardware design
- Antenna design
- Modeling of wall-penetration losses
- Performance and interference analysis, simulation, and testing
- Testing with 802.11b emitters

Highlight: Design Considerations

Approximate Loss Through Bricks

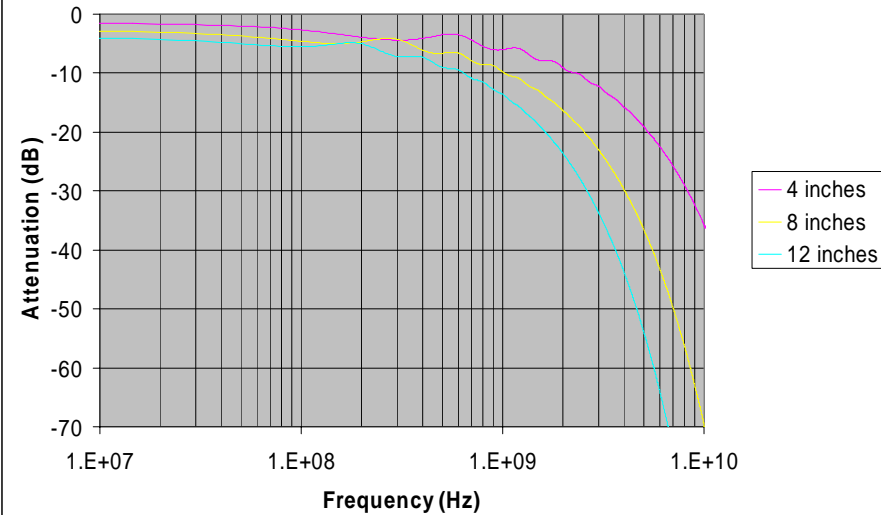

PN bursts Acquisition waveform

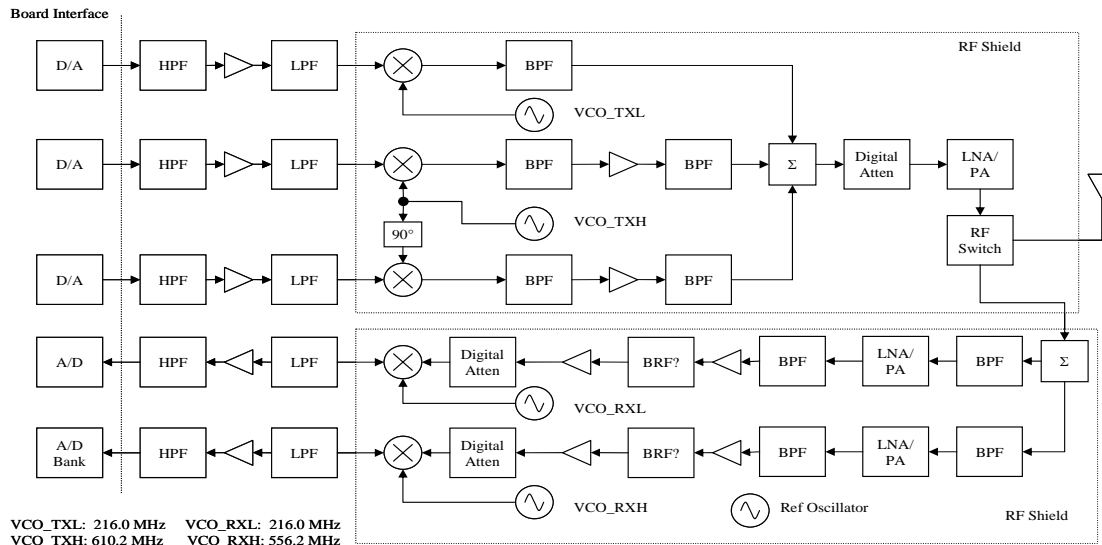
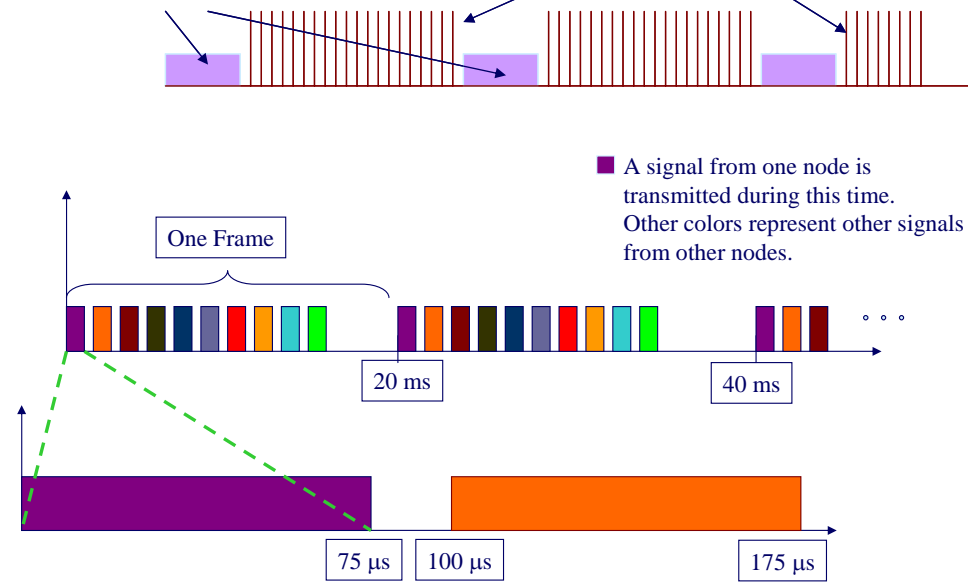

Highlight: Multi-Path Resolution Algorithms

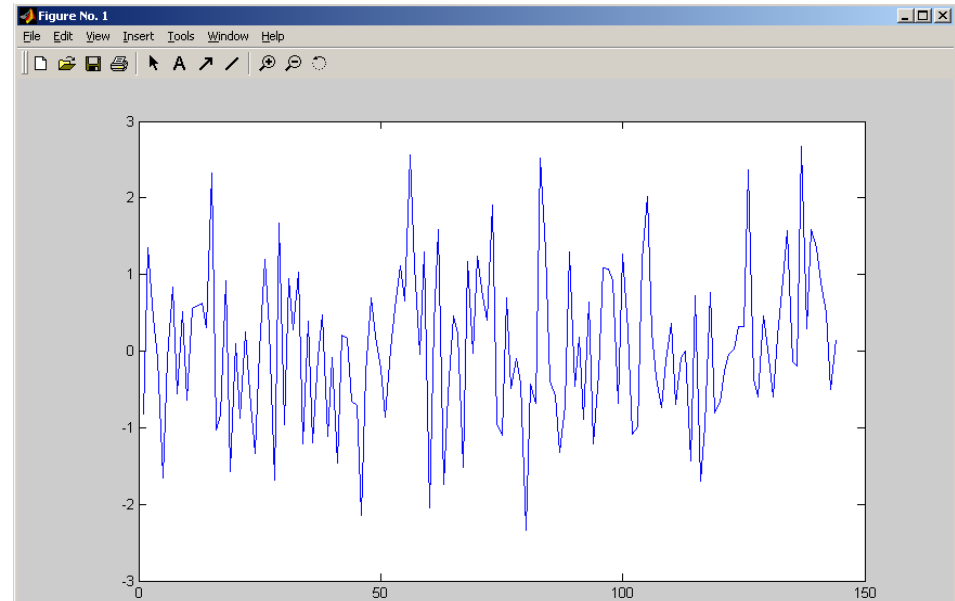
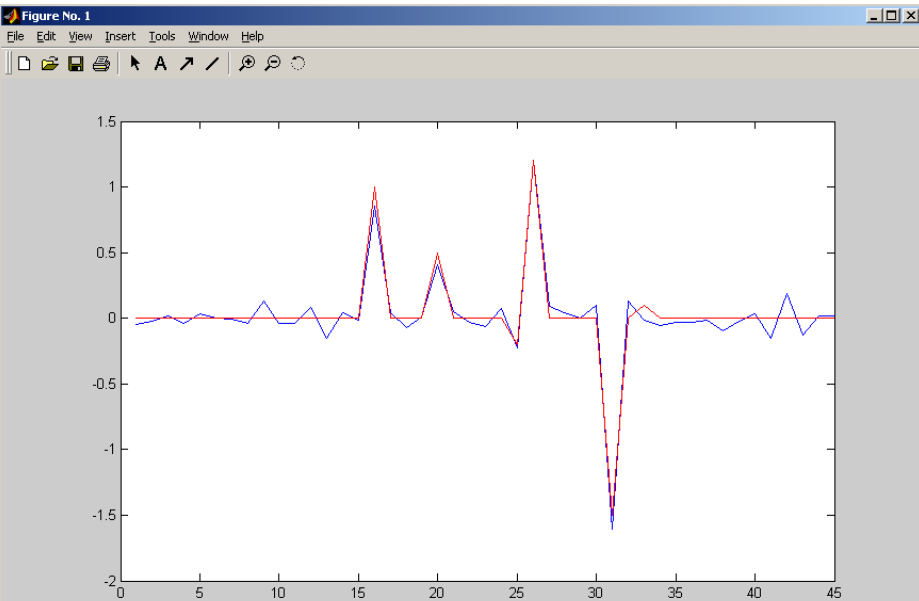
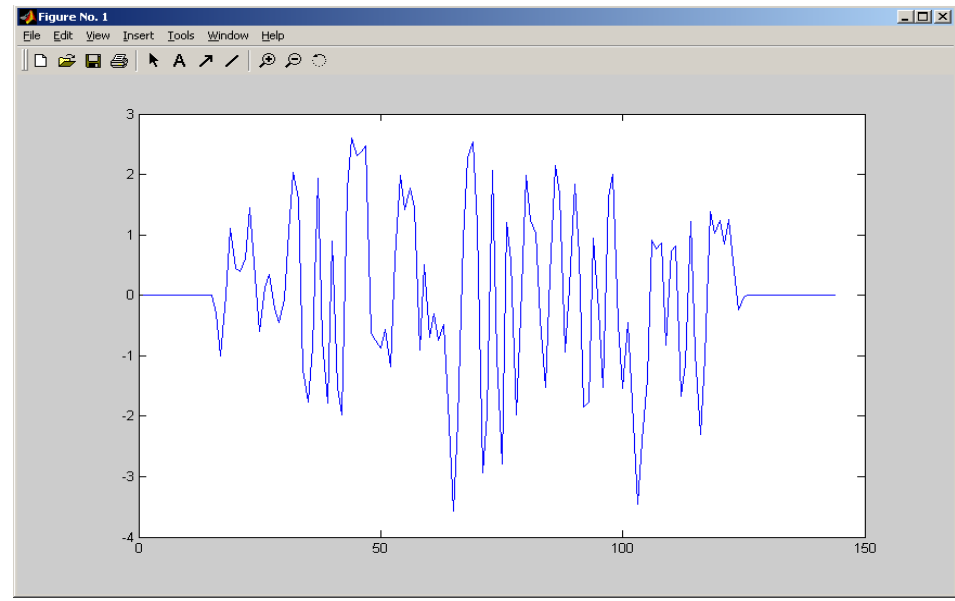
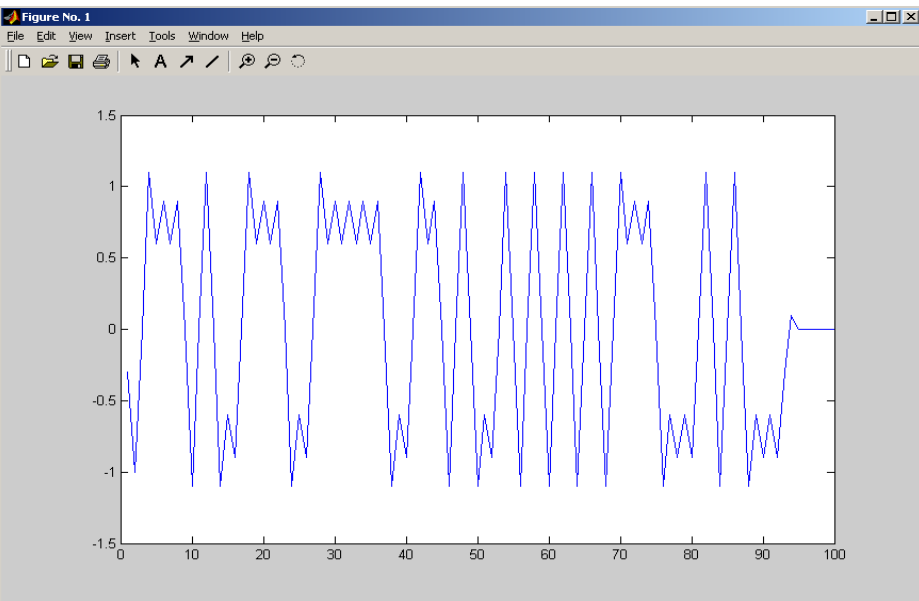

Impacts

- **Low rate communications can provide health and status of squad members**
- **Ranging will support in-building location determination**
- **These applications are important to:**
 - **Army small unit operations**
 - **Special Operations forces**
 - **Civil first responders**

Future Plans

- **Continued simulation of performance and potential interference**
- **Continued development of prototype system**
- **Testing with 802.11b emitters**
- **Testing of prototypes**
- **Results to provide input to FCC and National Telecommunications and Information Association (NTIA) decision-making process for UWB deployment**