

Incremental Capacity Upgrade Solutions for Existing Fiber Optic Links

Dr. Hatem Abdelkader

703-983-3131 abdelkader@mitre.org

Army-Contract MOIE

The logo for the MITRE Technology Program, featuring a stylized graphic of stacked blocks in yellow, orange, and blue to the left of the text.

MITRE
Technology
Program

Problem

- As demand grows current fiber optic links will need to be re-engineered to increase capacity
- Increasing the capacity using the current modulation is challenging due to increased linear/ nonlinear propagation impairments
- Proposed Solution: Advanced optical modulation techniques may allow:
 - Exploitation of the investment in legacy optical infrastructure (amplifiers and fiber)
 - Incremental funding of link upgrades

Background

- In order to ensure control of its critical communications infrastructure, the U.S. government has acquired long-term possession of a global fiber optic backbone.
- To fully exploit this backbone, the optical layer design and optimization must be actively managed; an effort complicated by:
 - Fiber topology heterogeneity (different fiber types)
 - Unique architectural and operational requirements (Network Operations differ from Telcos)
 - Churn in traffic termination points (due to dynamic BW demand and procurement process)

Objective

- Evaluate the benefits of advanced optical modulation formats, with focus on optical Differential Phase Shift Keying (DPSK)
- Demonstrate DPSK feasibility and quantify the resulting improvement in optical link aggregate bandwidth, length, and/or margin
- Assist industry in understanding the potential government market for advanced modulation
 - DPSK/NRZ modulation formats interoperability
 - D-QPSK feasibility (spectral efficiency & tolerance)
 - Experimental studies on GIG-BE-like links

Activities

- Design and build a 10 Gb/s DPSK transceiver (XCVR) unit on a laboratory breadboard, using discrete off-the-shelf components
- Characterize the XCVR unit to establish its back-to-back performance envelope
- Experimentally quantify the optical transport performance improvement when DPSK is used – instead of on/off keying – on optical test bed representative of GIG-BE links
- Evaluate the NRZ/DPSK modulation format's interoperability (on the same optical link)

Highlight: How Does DPSK Work?

- Transmitted data is encoded on the laser optical phase differentially between adjacent bits rather than in the amplitude.
- Decoding at the receiver is done via an optical delay-and-add Mach-Zehnder Interferometer. Here's how it's done:

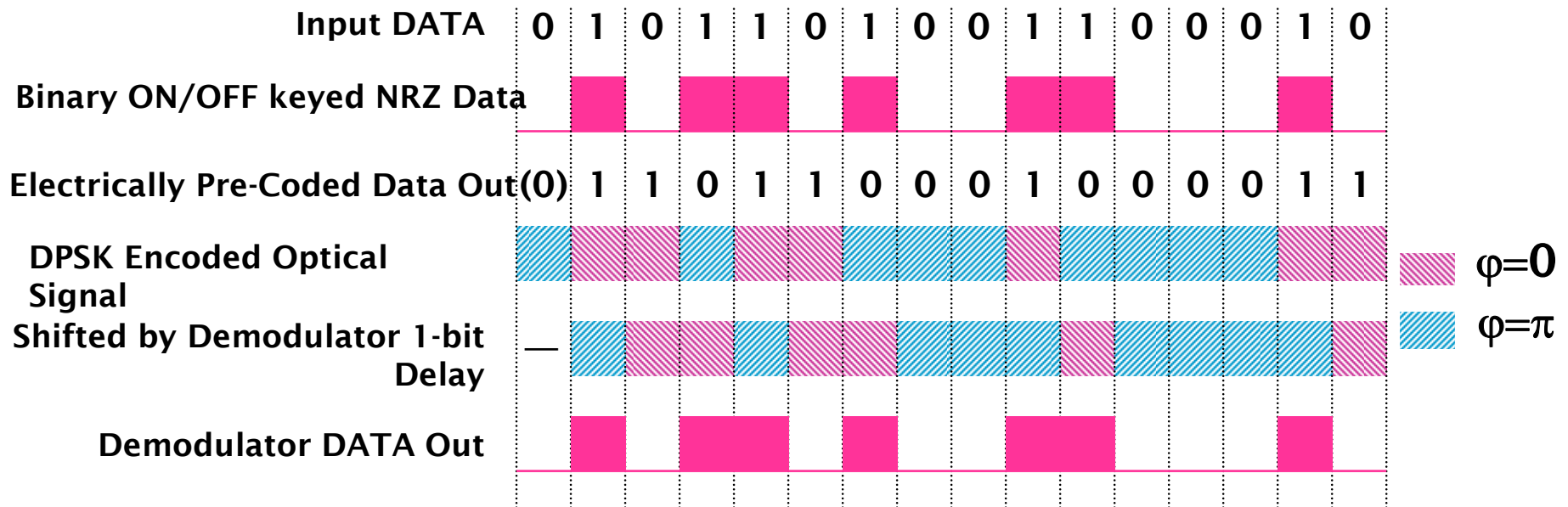

Highlight: DPSK XCVR Diagram

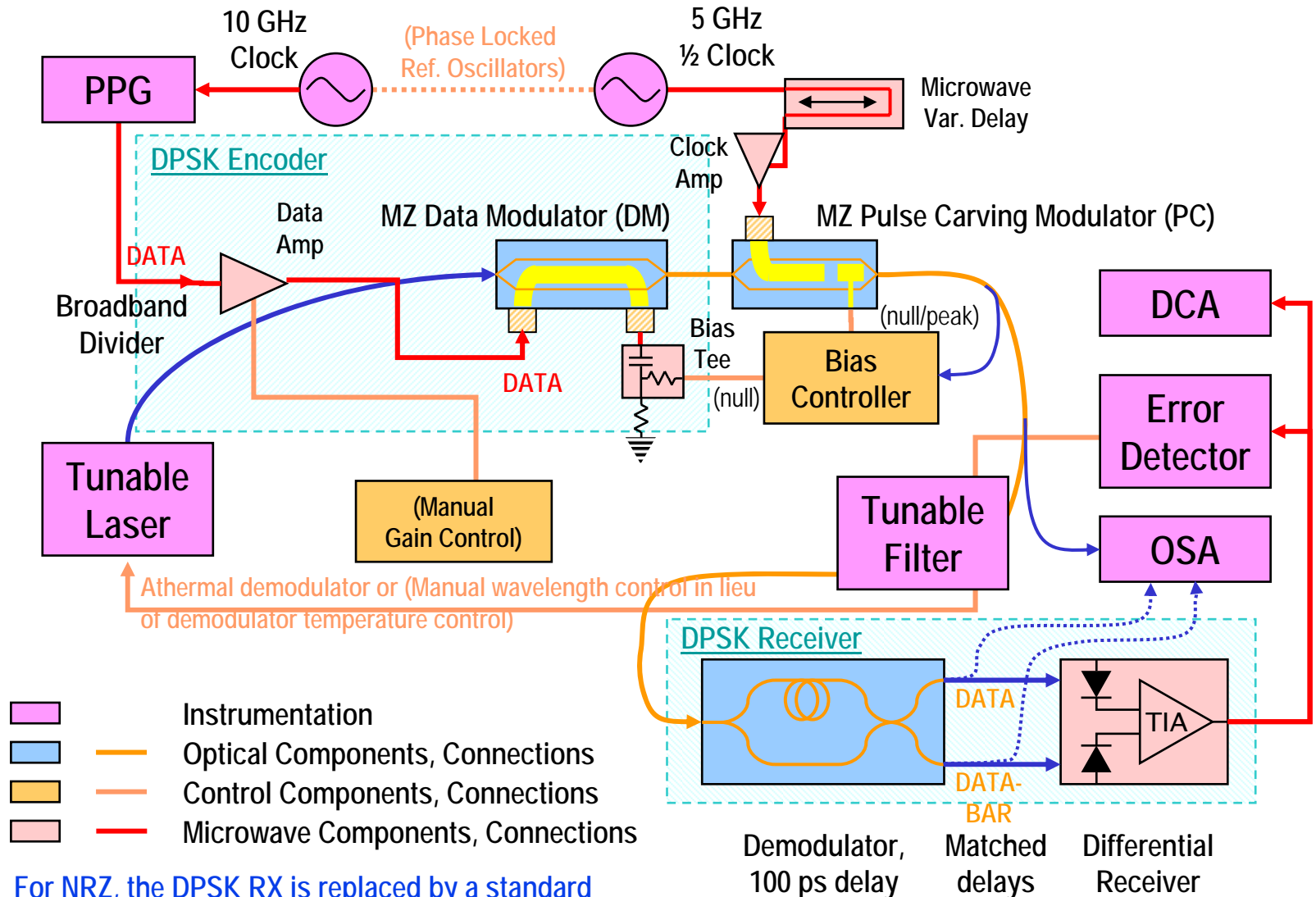

For NRZ, the DPSK RX is replaced by a standard PIN-TIA/limiting amplifier front end.

Highlight: DPSK XCVR Testbed Evaluation

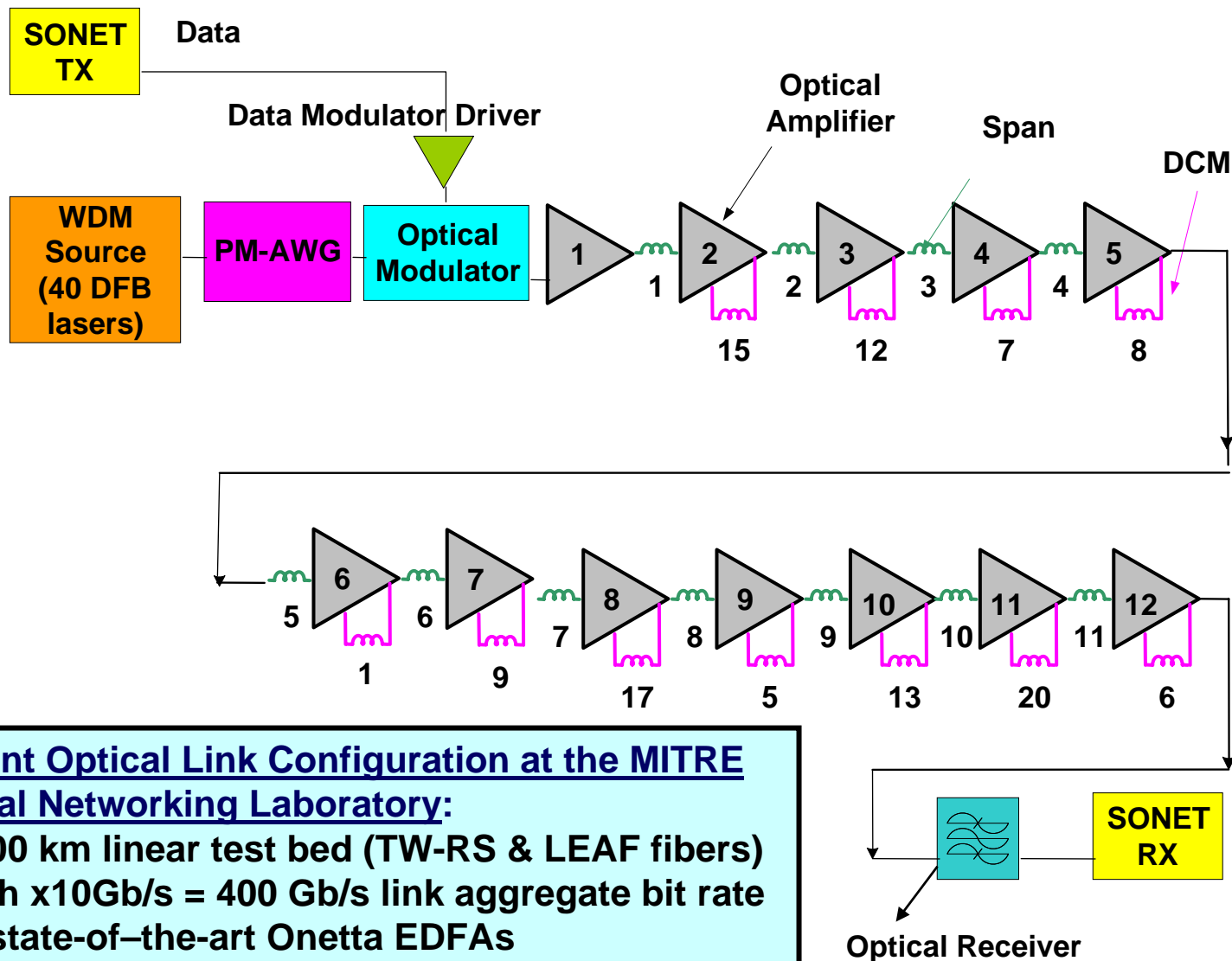

Current Optical Link Configuration at the MITRE Optical Networking Laboratory:

- 1,200 km linear test bed (TW-RS & LEAF fibers)
- 40ch x10Gb/s = 400 Gb/s link aggregate bit rate
- 12 state-of-the-art Onetta EDFAs
- 40 ch on 100 GHz ITU grid

Impacts

- Compared to NRZ, DPSK allows optical link operation with a 3-dB lower OSNR at the RX. This can potentially translate into a factor of two increase in link capacity
- Our sponsors can benefit from this work to:
 - Significantly increase the aggregate capacity of exhausted deployed links
 - Markedly extend the reach on these links
 - Improve the BER performance on marginal links (that are susceptible to outages due to transients caused by unplanned events)

Future Plans

- **Upgrade the DPSK XCVR to D-QPSK.**
Compared to binary on/off Keying, D-QPSK:
 - is 2 times more spectrally efficient, and 4 times more tolerant to CD & PMD distortions
 - has a narrow optical spectrum that can enable closer channel spacing (more capacity)
- **Investigate a coherent based DPSK RX:**
 - Effective electrical dispersion compensation
 - Higher RX sensitivity, and
 - Compatibility with several modulation formats