

# Dual Use of Commercial Avionics Data Links for the U. S. Air Force

Mary M. Girard, Richard F. Brady  
The MITRE Corporation  
Center for Air Force C2 Systems  
Bedford, Massachusetts

Capt. Stephen W. Hill  
United States Air Force  
Electronic Systems Center  
Hanscom Air Force Base, Massachusetts

## ABSTRACT

*The International Civil Aviation Organization (ICAO) has endorsed a concept for future aeronautical communications, which uses digital data links to supplement voice communications and provide improved air traffic services. As the civil-controlled airspace moves toward requiring new communication capabilities, the military will need to equip their aircraft if worldwide-unrestricted airspace access is to be maintained. This paper covers the new civilian data link requirements and USAF experiments demonstrating the utility of these data links for military airlift command and control systems.*

## 1. INTRODUCTION

The International Civil Aviation Organization (ICAO) and the civil aviation community are implementing a concept for advanced communications, navigation, and surveillance (CNS) systems to improve air traffic management (ATM). This new CNS/ATM concept relies heavily on specific avionics data links qualified to transmit air traffic control messages. These data links are covered in section 2.

The need to conduct operations worldwide, in peacetime and in times of crisis means that military aircraft must operate in civil-controlled airspace and comply with future ICAO requirements to gain access to favorable oceanic tracks. Denial of the best oceanic tracks, including optimal altitudes, and certain mission critical airspace may lead to serious degradation in DOD mission accomplishment. In 1996, the U.S. Air Force's Electronic Systems Center (ESC) carried out a study for Headquarters Air Mobility Command (HQ AMC) which assessed the requirements, primarily for large transports, for operation in the new communication environment [1,2,3]. HQ AMC specified the need for the communications capabilities for airlift/tanker aircraft, and in 1997 the Air Force created a global air traffic operations/mobility command and control (GATO/MC<sup>2</sup>) system program office (SPO) at ESC to evaluate and identify the development and procurement activities necessary to meet these new civil and military air traffic requirements. Section 3 discusses the GATO/MC<sup>2</sup> SPO activities.

The Air Force JEFX99 Initiative 99-018 demonstrated the use of civilian avionics data links to support air operational command and control communications. This initiative was a combination of a number of separate activities performed by AMC, Air Force Research Labs (AFRL), ESC, and a variety of commercial vendors including ARINC, Honeywell, Bremer, and AlliedSignal. Section 4 discusses this JEFX99 architecture and section 5 provides some conclusions.

## 2. CIVIL AVIATION DATA LINKS

Currently, most communications between aircraft and air traffic controllers rely on analog voice links. ICAO's new CNS/ATM concept employs avionics data links as the key enabler to achieve improvements in air space management. To obtain worldwide air/ground link capability, ESC's 1996 CNS/ATM study recommended that AMC install an avionics system with integrated data links compliant with civil aviation authority projected requirements on military aircraft. This would require that the military equip their aircraft with dual beyond-line-of-sight (BLOS) data links, and in the long term, line-of-site (LOS) data links. These links must comply with ICAO requirements for aeronautical mobile satellite services (AMSS). Currently, only the Inmarsat satellite system meets AMSS requirements and has been approved for use as a BLOS ATS data link. ICAO has recently completed the Standards and Recommended Practices (SARPs) for an HF data link (HFDDL) which will allow it to be evaluated by civil aviation authorities as an ATS data link. The Minimum Aviation Systems Performance Standard (MASPS) and Minimum Operational Performance Standard (MOPS) for HFDDL are also under development by the avionics industry. The military, along with several airlines, are encouraging this use of HFDDL as a backup BLOS data link due to the large installation cost of the Inmarsat system and since many military aircraft are already equipped with HF radio systems for voice operation.

The LOS data link used today by the avionics industry is the Aircraft Communications Addressing and Reporting System (ACARS) VHF data link (VDL) Mode 0. VDL Mode 0 is

used primarily for airline operational control (AOC) functions but is also used for pre-departure clearance and supports air traffic services (ATS) messages as part of the FANS-I system. Several VHF LOS data links are under development, including VDL Mode 2, VDL Mode 3, and VDL Mode 4. The FAA data link migration plan supports the use of VDL Mode 2 for non-critical ATS communications, with transition of data link services to VDL Mode 3. While VDL Mode 2 is a digital data link only service, VDL Mode 3 supports both digital data and digitized voice communications. The FAA plans transition to VDL Mode 3 around 2011. ICAO has recommended VDL Mode 3 for line of sight voice and data link ATC communications, although it appears the implementation of this line of sight system will occur much later than the BLOS systems. VDL Mode 4 is being developed primarily by the European avionics industry to address applications such as broadcast of position reporting in a free-flight environment. The management of the data links, including choice of media, will require the addition of a communications management function (CMF) with router software specific to the Aeronautical Telecommunications Network (ATN), and will require supporting data link applications. Two applications are expected to serve ATS communications: Controller-Pilot Data Link Communication (CPDLC) and Automatic Dependent Surveillance (ADS). CPDLC includes a set of messages specific for ATS replacing many voice transmissions and ADS facilitates the transmission of aircraft position reports.

### **3. DOD IMPLICATIONS**

As stated earlier, the GATO/MC2 SPO was created to support the implementation of these data links and other CNS/ATM capabilities. Some of the primary areas of concern for the GATO/MC<sup>2</sup> SPO are: 1) understanding, influencing, documenting, and disseminating the CNS/ATM technical and performance requirements that impact USAF flight operations; 2) coordinating the transition of CNS/ATM and related command and control solutions into airborne platforms and ground infrastructures (including technology roadmaps for evolutionary compliance with developing requirements and for dual use of equipment for military and civil enhanced capabilities); 3) optimizing the common acquisition of CNS/ATM avionics, ground infrastructure, and logistics support; and 4) assisting the major commands (MAJCOMs) and platform SPOs in planning, programming, and budgeting for CNS/ATM and related command and control solutions. The scope of these activities includes all airborne communications, navigation (and landing), and surveillance functions that are relevant to worldwide civil aviation operations.

In order to accomplish these objectives, the GATO/MC2 SPO has developed a strategic role in both the civil and military avionics and command and control communities. First, the SPO participates in the relevant technical performance and standards development committees for civil airspace to

ensure military requirements are considered and to document and disseminate these technical requirements to the DOD community. The SPO also supports the platforms in the development and selection of avionics architectures that will support current and future CNS/ATM requirements to ensure global access. The SPO has set up several contracts for commercial/military avionics equipment, including Inmarsat Aero-I radios, HF Data Radios, and Communication Management Units (CMU)s that meet civil airspace requirements. These contracts and the logistics support strategy associated with them have served to optimize the common acquisition and support of CNS/ATM avionics. Finally, the SPO has set up a reconfigurable cockpit and avionics testbed (RCAT) to support R&D activities focused on (1) interoperability experiments among the civil avionics equipment, and (2) advanced concept experiments to evaluate the use of CNS/ATM capabilities to support military command and control activities. The rest of this paper will focus on this last effort of increasing USAF command and control capability through “dual use” of these CNS/ATM avionics.

### **4. JEFX-99 EARLY INTEGRATION TESTS IN A GLOBAL MOBILITY ENVIRONMENT**

Air Force JEFX99 Initiative 99-018 demonstrated the use of civilian avionics data links to support military command and control communications and allowed the USAF operational evaluation of the capabilities enabled by the use of these data links. This initiative demonstrated:

- A limited total asset visibility (TAV) capability via the civilian data links, CMU, and ARINC network.
- The potential for a robust TAV capability via the AFRL Information For Global Reach (IFGR) program.

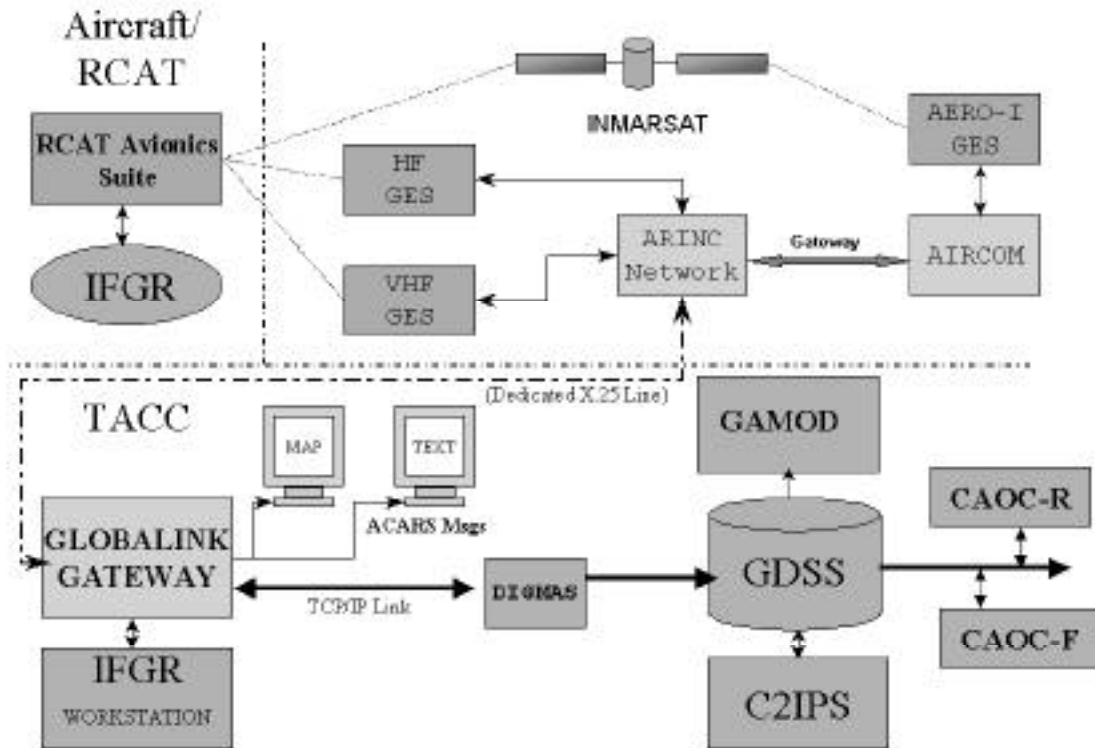

Figure 1. AMC/JEFX99 Initiative, System Architecture

Figure 1 is an overview of the system architecture that supported message traffic between the RCAT and the USAF Tanker Airlift Control Center (TACC). The RCAT avionics suite simulates an aircraft and contains the civilian data links required to transmit and receive ACARS messages. Initial RCAT air/ground messaging capability supports a variety of message traffic including arrival, departure, position reports, expected time of arrival updates, diversion reports, and free text information. The RCAT also supported avionics uplink messages such as pre-departure clearance, digital air traffic information services (ATIS), and free text. The message traffic from the RCAT is sent via RF communications paths (HF, VHF, and SatCom) to the ACARS telecommunications network. The ACARS network forwards the message to a GlobalLink Gateway (an ARINC product) installed within the TACC. The Dynamic Information Gateway Management System (DIGMAS), installed at the TACC, filters the RCAT generated messages from the ARINC GlobalLink Gateway, translates them to the SQL format required by the Global Decision Support System (GDSS), and sends them to the GDSS. GDSS forwards aircraft movement information to designated Combined Air Operations Control (CAOC) centers for operational evaluation. This message processing thread demonstrated the delivery of near real time mission

aircraft movement information via civilian data links and the ACARS network.

The RCAT is an integration and test facility created by ESC/GA to support USAF AMC during fleet modernization with CNS/ATM systems. The testbed is located at The MITRE Corporation in Bedford, MA. Figure 2 is a functional block diagram of the RCAT equipment used in the JEFX99 initiative.

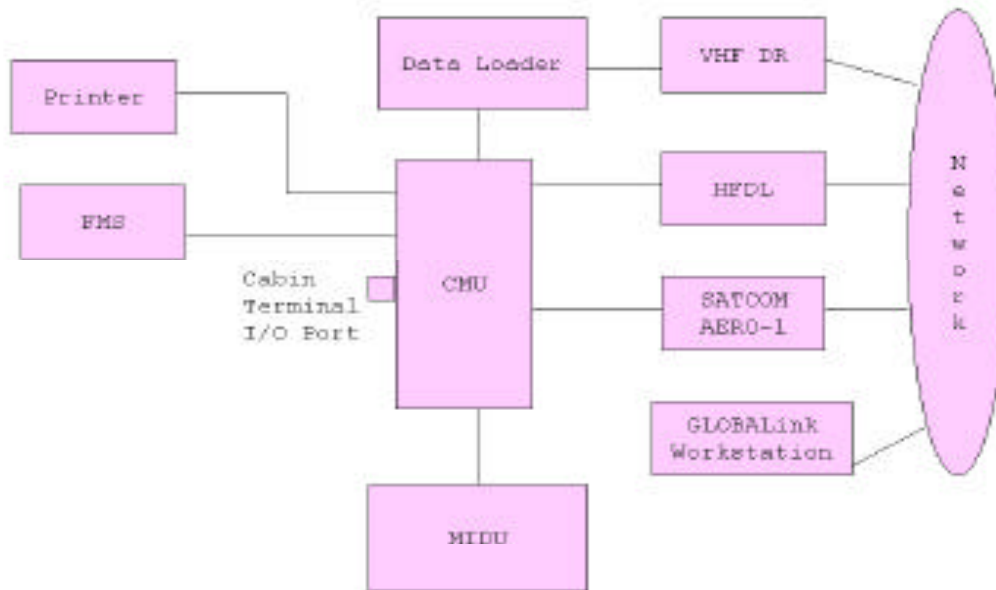

Figure 2. RCAT Functional Block Diagram

As shown in figure 2, the RCAT includes a commercial flight management system (FMS) which provides a flight plan and aircraft flight control system information to the CMU for use in simulations. The CMU manages the ACARS message set and avionics communications data link routing. The multi-function interface display unit (MIDU) is an avionics display that is the primary pilot interface for message generation/reception. The three data links include a VDL Mode 0, an HF data radio (HFDR), and a SatCom data radio (Inmarsat Aero-I). A commercial data loader is used to install operational software and data base updates into the FMS and

CMU. An avionics printer is also included which is primarily used to support message operations.

During this JEFX99 initiative test program, the RCAT supported the following functions:

- **Virtual Aircraft** - Provided a platform for message generation and reception representing an aircraft supporting AMC missions. The virtual aircraft utilized the re-configurable flight deck avionics suite outfitted with CNS/ATM and COTS equipment installed in a mockup of a generic AMC aircraft flight deck. This initial RCAT capability supported the exchange of ACARS messages with the TACC. Future RCAT functions include integration of tactical communication links (e.g. VHF, HF, UHF, and SatCom) into the command suite.
- **Ground Messaging Center** - A Windows 95/NT or UNIX Globalink workstation simulated an avionics AOC workstation. The workstation(s) located within the

RCAT is used to evaluate and optimize the performance of the flight deck. This methodology allows end-to-end RCAT testing independent of the TACC or the “live” ARINC network avionics suite(s), which is part of the virtual aircraft.

The RCAT’s CMU cabin terminal port was used to interface the IFGR equipment to the RCAT avionics test suite. The IFGR workstation simulated an airborne command and control information management system used during a typical mission. For the purposes of the JEFX99 initiative the IFGR workstation also simulated messages from multiple (up to five) aircraft and included an enhanced set of user defined messages. The IFGR workstation employed the RCAT avionics suite to transfer simulated mission message traffic to and from the TACC via the ACARS network. The IFGR workstation used the RCAT cabin terminal interface to send the same ACARS messages that the RCAT sends as well as transmitting additional data such as weather graphics enveloped in an ACARS message. The IFGR generated ACARS messages, once received at the TACC, were sent to GDSS via DIGMAS as well as being provided to the IFGR workstation. Weather graphics data was sent to the IFGR workstation for processing and display. The transmission of this data demonstrated robust, two-way TAV messaging capabilities, beyond the ACARS message set.

The AFRL IFGR program goal is to develop a communications capability to maximize the utilization of all available commercial and military communication bandwidth on the aircraft. The initial step of the AFRL program was to take advantage of the civilian data links that are being installed as part of the DOD CNS/ATM upgrades.

As shown in Figures 1 and 2, the IFGR testing executed at two nodes, one in the RCAT and one in the TACC at Scott AFB. The testing required the RCAT CMU and data links, ARINC's Globalink network and Workstation, the IFGR Workstations, the IFGR Intelligent Information Manager and the Intelligent Adaptive Communications Controller application software. This testing assessed the value of the integration of selected communications and information management related technologies to improve and enhance the operational C4I capability available to AMC and its supporting elements in the world-wide air mobility environment. It demonstrated the utility of robust TAV capability that included additional information beyond the aircraft movement information provided by the CNS/ATM mandated GATM. IFGR testing included numerous formatted and free-text messages transmitted between the IFGR workstation and the aircraft avionics at the RCAT and TACC nodes. The timing of transmission and receipt of these messages, in conjunction with objective and subjective assessments of the applicability of the information to the enhancement of AMC's operational mission, will be the basis for determining the degree to which objectives were satisfied.

For TAV including reach back from the aircraft to the TACC, data communications were initiated from both the CMU and the IFGR workstation in the RCAT. This simulated transmission of updated information on the status of the mission and reach back. For reach forward from the TACC to the aircraft (RCAT) for multi-media connectivity, data communications were initiated from the IFGR workstation in the TACC.

## 5. CONCLUSIONS

There are a number of Federal, DOD, and USAF documents that require military aircraft to comply in peacetime with civil aviation requirements in civil-controlled airspace. In order to comply, the military is beginning to equip with CNS/ATM data links. Manufacturers are addressing the use of civil data link systems on military aircraft by developing solutions that port the civilian HFDL hardware and software onto circuit cards for installation into military HF radios. The addition of VDL Mode 2 and VDL Mode 3 protocols to military radios is being handled in a similar manner for VHF radios. Interfaces to a commercial off-the-shelf CMU are also being developed for military radios and for the military-specific flight management systems.

The addition of these mandated CNS/ATM capabilities to the USAF fleet via the ESC/GATO MC2 SPO activity enables an USAF AOC capability applied to command and control issues. This initiative demonstrated the operational utility gained by the use of this capability to improve global management of USAF mobility forces, taking advantage of the networking infrastructure already in place for commercial airlines. As the civil avionics service providers implement

planned upgrades to their networks, eventually moving to the ATN, it is expected that the USAF will continue to capitalize on these improvements, as the industry moves to a free-flight environment.

The RCAT demonstrated that a USAF MAJCOM could procure CNS/ATM COTS equipment, integrate the equipment in a typical USAF avionics suite, and employ the equipment to assist mission objectives. The RCAT also demonstrated that the CMU's cabin terminal port can be used for additional applications providing utility to the military mission.

A primary military issue not addressed by this initiative is security. Military aircraft will require the ability to inhibit transmission of data using ATC data links. In addition, the military use of these data links may require encryption of the data and the aircraft's tail number. The primary issue is that the tail number can be extracted from the network address and the aircraft's future position may become compromised. The issue of authentication between controller and pilot digital data messages is another important area for consideration by the military. ICAO is currently developing enhancements to the future networking standards to allow for authentication of application information, routing information, and systems management information exchanges. The authentication standards may need to be completed before widespread implementation of ATN occurs by the military

## ACKNOWLEDGEMENTS

The authors are grateful to Mr. Michael Bernock, GATM RCAT Manager, and Lt. Darren Edmonds, Project Manager Advanced Development C<sup>2</sup>, for reviewing this paper and providing beneficial comments. Special thanks go to Ms. Nancy Gennell, support staff, for preparing this paper for publication.

## REFERENCES

- [1] Salamone, et al., Air Mobility Command (AMC) Communications, Navigation, and Surveillance/Air traffic Management (CNS/ATM) Study: Requirements Report, MP 96B0000129, The MITRE Corporation, Bedford, MA, December 1996.
- [2] Salamone, et al., Air Mobility Command (AMC) Communications, Navigation, and Surveillance/Air traffic Management (CNS/ATM) Study: Architecture and Cost Report, MP 97B0000001, The MITRE Corporation, Bedford, MA, January 1997.
- [3] December 1996, Air Mobility Command CNS/ATM Study: CNS/ATM Interoperability Requirements Report, Air Traffic Control and Landing Systems Program Office, Electronics Systems Center, Hanscom AFB, MA (Rev. 1)